

OPTIONS: Special reflective surfaces, add suffix:

- T** 1/4" tempered glass mirror
 - L** 1/4" laminated glass mirror
 - SS** 20 gauge 430 bright anneal stainless steel
- Custom sizes available

**"2S" LOCKING DESIGN
(Rear View)**

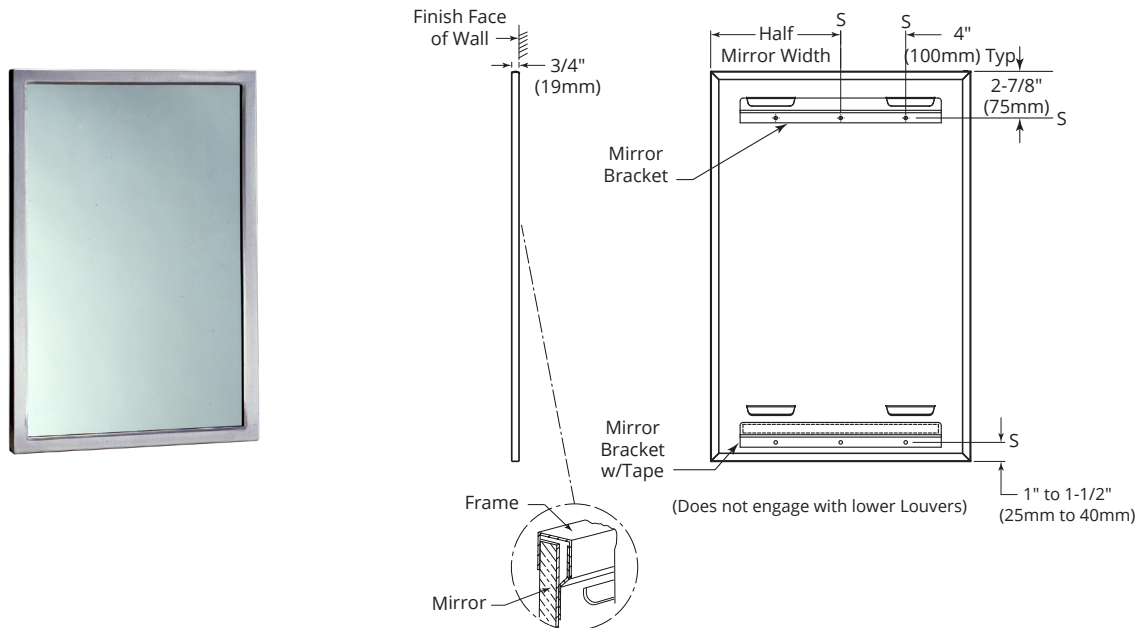

STANDARD A-SERIES MIRRORS

MODEL NO.	OVERALL SIZE	
	W	H
A-18 x 24	18" (46cm)	24" (61cm)
A-18 x 30	18" (46cm)	30" (76cm)
A-18 x 36	18" (46cm)	36" (91cm)
A-18 x 60	18" (46cm)	60" (152cm)
A-24 x 30	24" (61cm)	30" (76cm)
A-24 x 36	24" (61cm)	36" (91cm)
A-24 x 48	24" (61cm)	48" (122cm)

STANDARD A-SERIES MIRRORS

MODEL NO.	OVERALL SIZE	
	W	H
A-24 x 60	24" (61cm)	60" (152cm)
A-24 x 72	24" (61cm)	72" (183cm)
A-36 x 36	36" (91cm)	36" (91cm)
A-48 x 30	48" (122cm)	30" (76cm)
A-48 x 36	48" (122cm)	36" (91cm)
A-60 x 36	60" (152cm)	36" (91cm)
A-72 x 36	72" (183cm)	36" (91cm)

Note: Mirrors greater than 36" in width will have multiple hanger bracket pockets with a typical 8" off each edge

CONSTRUCTION:

Frame — Fabricated of heavy-gauge stainless steel, 3/4" x 3/4" (19 x 19mm) angle with # 4 satin finish. One piece, construction. Corners are welded and ground smooth.

Back Panel — Fabricated of galvanized steel with slots formed to receive wall hanger tabs. Shock absorbing material is placed between mirror and back panel.

Standard Mirror Glass — #1 quality, 1/4" (6mm) plate/float glass guaranteed against silver spoilage for 15 years. Meets and exceeds federal specifications DD-M-00411B & C. S. 27.

continued . . .

SPECIAL REFLECTIVE SURFACES:

These surfaces resist breakage and provide a measure of safety from broken glass, but differ in color and reflective quality from standard glass mirrors.

INSTALLATION:

Surface-mounted. Mirror installs on concealed vandal-resistant wall hangers. See wall instructions to locate mirror wall hangers. Secure to wall with 6 #10 x 1-1/2" (38mm) flat head full threaded screws. Hang mirror on wall hanger and secure double-sided tape to mirror back to lock mirror in place.

ADA GUIDE:

Access to mirrors should be 40" (1016mm) from bottom edge of reflective surface to the finish floor. Full length mirrors will accommodate all facilities.

"S2" Tab Design — Double-sided tape secures mirror to concealed wall hanger when it is lowered into final position.

**"S2" TAB DESIGN
(Front View)**

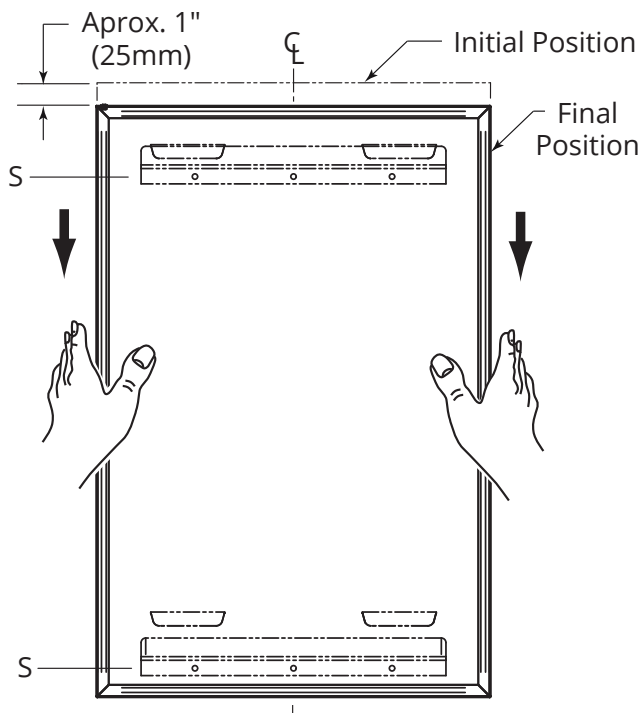

Welded-Frame Mirror shall be Model _____ A-Series (insert size) of Gamco Commercial Restroom Accessories, A Division of Bobrick Washroom Equipment, Inc., One Gamco Place, Durant, OK, 74701-1910