

CG-2 1-1/2" W x 48" H x 1-1/2" D (28 x 1219 x 38mm) 18-gauge
(1.2mm) adhesive supplied

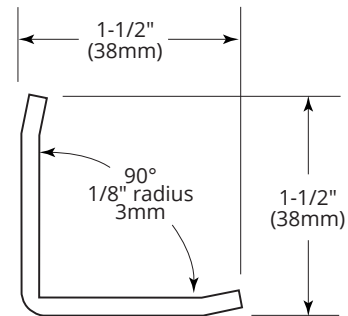
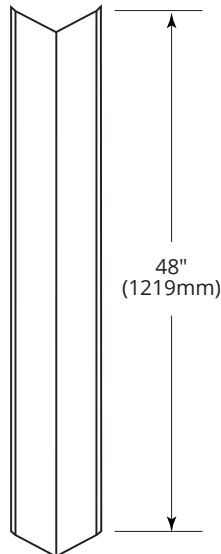

CONSTRUCTION:

Unit fabricated of type 304 HEAVY GAUGE stainless steel with exposed surfaces having a #4 satin-finish. Units bent on a 1/8" (3mm) radius to form a 90° angle. Units provided with huggd edges for safety and to conceal minor wall irregularities.

Furnished with double-faced adhesive tape.

OPTIONS:

Custom styles and sizes available for all corner guards shown above.

Corner Guards shall be Model _____ (insert model number) of Gamco Commercial Restroom Accessories, A Division of Bobrick Washroom Equipment, Inc., One Gamco Place, Durant, OK, 74701-1910